

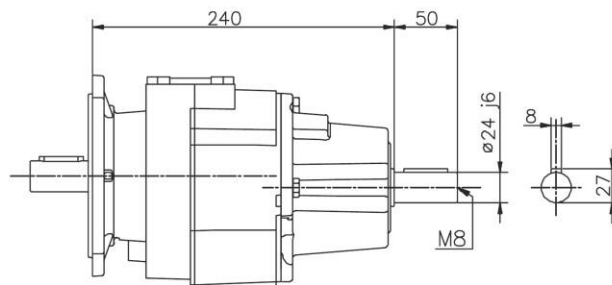

Редуктор, Мотор-редуктор CH030 MOTOVARIO

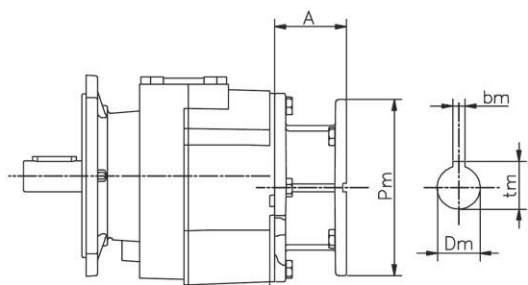
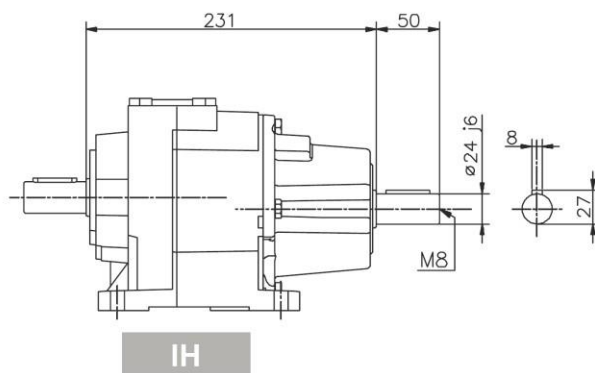
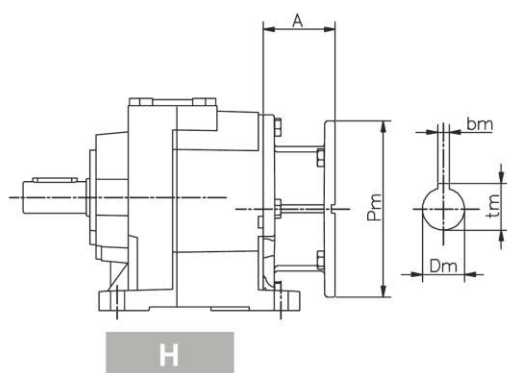
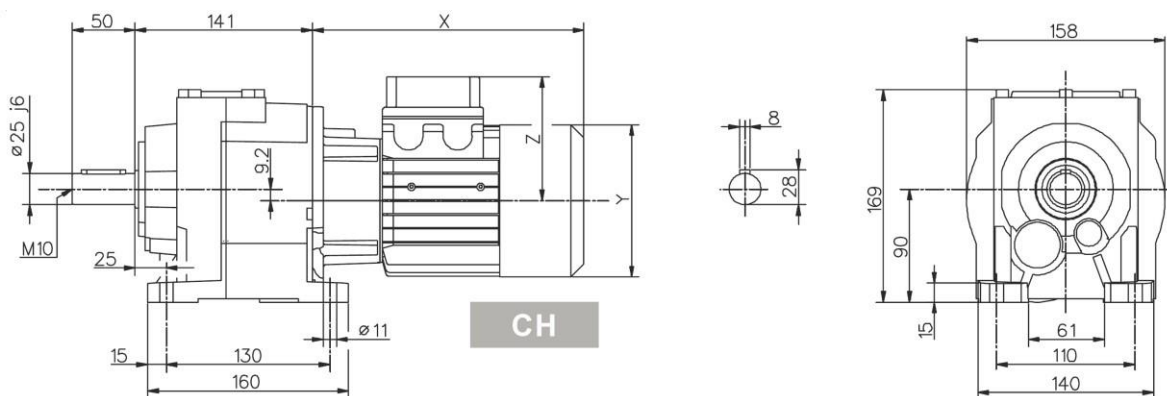

H...F FA-FB-FC-FD

IH...F FA-FB-FC-FD

030	IH	PAM		Motore normale / Standard motor / Normaler Motor / Moteur normal / Motor normal				Motore autofrenante / Brake motor / Bremsmotor / Moteur frein / Motor-freno			
	~Kg	A	~Kg	X	Y	Z	~Kg	X	Y	Z	~Kg
63	12.2	57	9.1	215	121	104	12.6	273	121	119	14.1
71		69	9.5	241	139	112	13.5	305	139	128	15.7
80		90	10.1	268	158	122	18.2	341	158	137	21.7
90s		90	10.1	296	173	130	22.1	373	173	130	27.6
90l		90	10.1	321	173	130	24.1	398	173	130	29.6
100		105	14.4	333	191	139	29.6	415	191	139	35.1
112		105	14.4	351	211	154	41.1	448	211	154	50.8